

16-Way Input Expansion Board – Rev 1.1

CONNECTING THE POWER TO THE INPUT BOARD

You must connect 12 volts DC to power each input board.

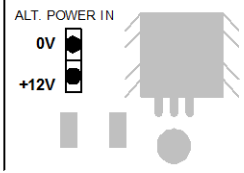

Warning: The +12 Volts connection pin is opposite to the CS Network Controller power connection.

Be Careful!!

You must allow 0.5 Amp current consumption for each input board.

BOARD LINK SETTINGS:

LK17 – UP (JP19)
LK18 – OFF (test link)

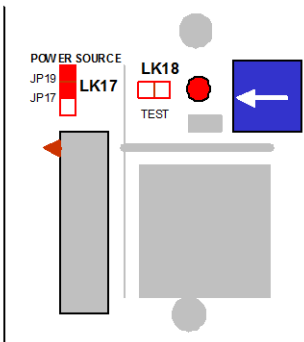

INPUT BOARD ADDRESSING:

Each 16-way expansion input board must have a unique address for the controller it is connected to. This is set using the small rotary switch.

The first board connected to the controller is usually address 0, the next board is address 1 and so on.

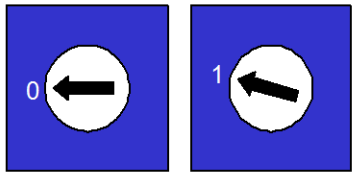

Note: Relay boards can have the same address as the Input boards.

CONNECTING THE INPUT BOARD TO THE CONTROLLER

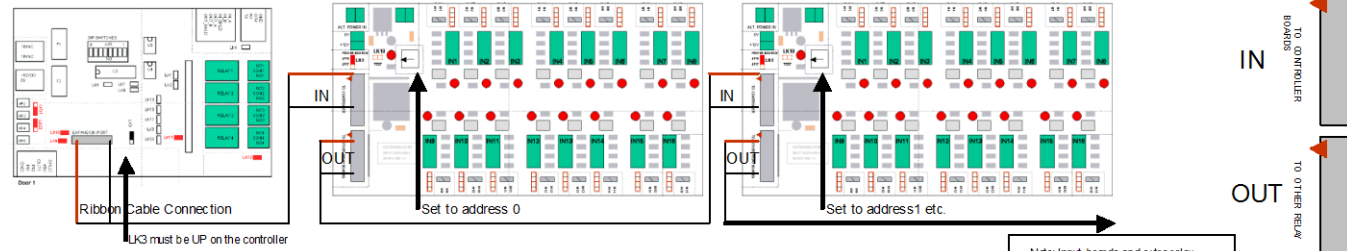

Use the ribbon cable to connect the input boards to the controller. The red line on the ribbon cable indicates pin 1.

On the controller Pin 1 is to the left. On the input board pin one is on the top. Connect the ribbon cable as shown above.

Note: Do not connect the ribbon cables while the power is on the controller or input board.

Note: Input boards and extra relay boards may be added on the bus as required.

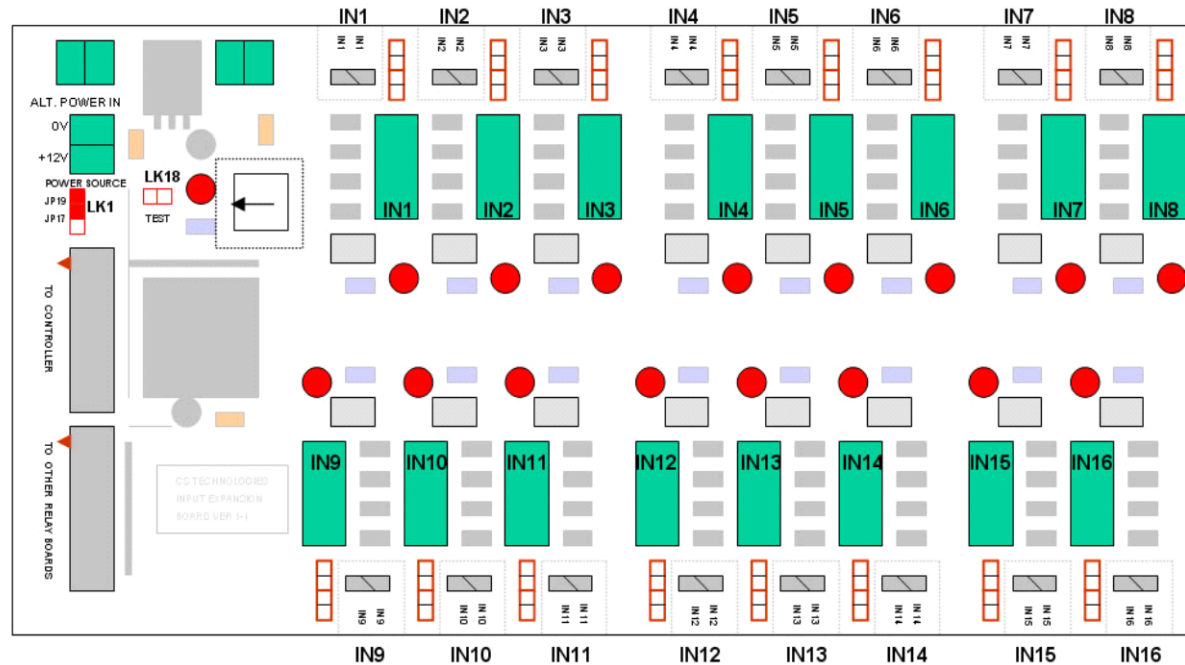

DRY CONTACT INPUT OPTION:

Connect as shown below for dry contact inputs.

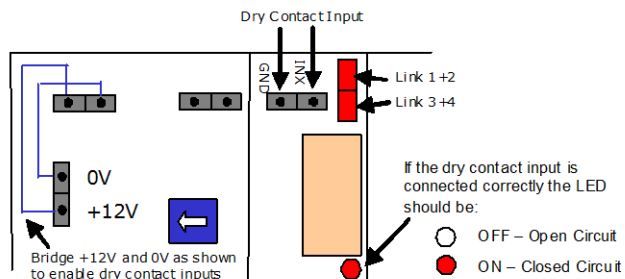

DC VOLTAGE INPUT OPTION:

Connect as shown below for voltage inputs.

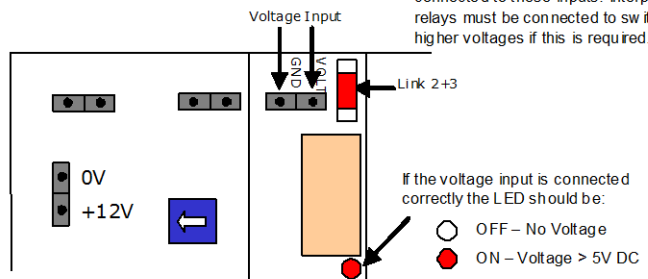

Note: Under no circumstances should voltages higher than +/-30V DC be connected to these inputs. Interposing relays must be connected to switch higher voltages if this is required.