

# MultiTransmitter Fibra User manual

Updated May 4, 2023



**MultiTransmitter Fibra** is an integration module connecting third-party wired devices to an Ajax security system. It has 18 zones for connecting NC, NO, EOL, 2 EOL, and 3 EOL devices.

MultiTransmitter Fibra is equipped with two tampers for protection against dismantling. The device is powered from the 110–240 V~ mains, and can also be powered from the 12 V= backup battery. It can supply 12 V= power to connected devices.



The integration module is compatible with [Hub Hybrid \(2G\)](#) and [Hub Hybrid \(4G\)](#). Connection to other [hubs](#), [radio signal range extenders](#), [ocBridge Plus](#), and [uartBridge](#) is not provided.

MultiTransmitter Fibra works as part of an Ajax security system, exchanging data with the hub using the secure Fibra wired protocol. The wired connection range is up to 2,000 meters when using a U/UTP cat.5 twisted pair.

MultiTransmitter Fibra is a product of the Fibra wired lineup. The installation, sale, and administration of these devices are performed only by accredited Ajax partners.

## Buy MultiTransmitter Fibra

## Functional elements

## Casing elements

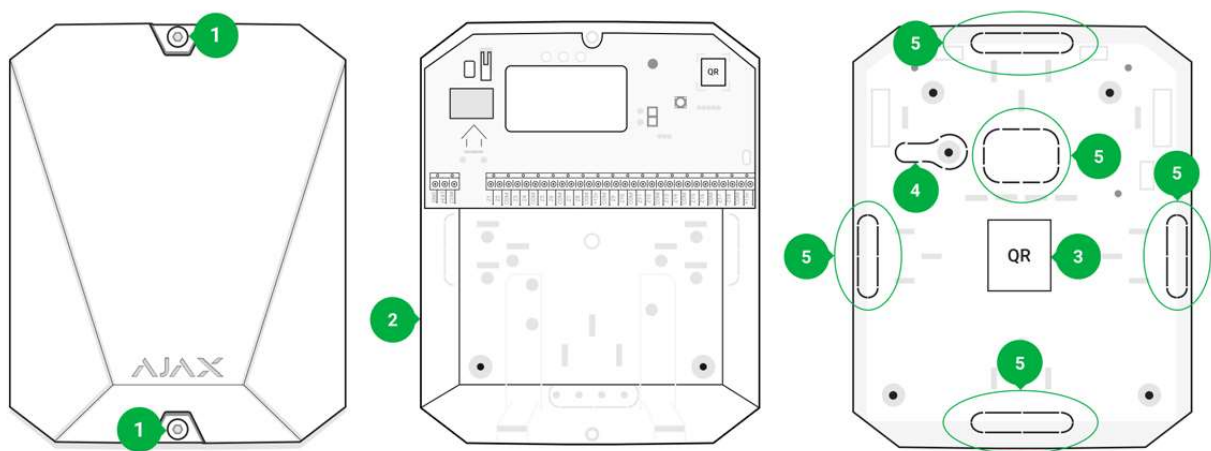

1. Screws securing the casing lid. Unscrew with a bundled hexagon key ( $\varnothing$  4 mm).
2. Space for a 12 V= backup battery.



Backup battery is not included in the MultiTransmitter Fibra complete set.

3. MultiTransmitter Fibra QR code and ID (serial number). It is used to pair the device with the Ajax security system.
4. Perforated part of the casing. Necessary for tamper triggering in case of any attempt to detach the device from the surface. Do not break it off.
5. Perforated parts of the casing for cable output.

# Board elements

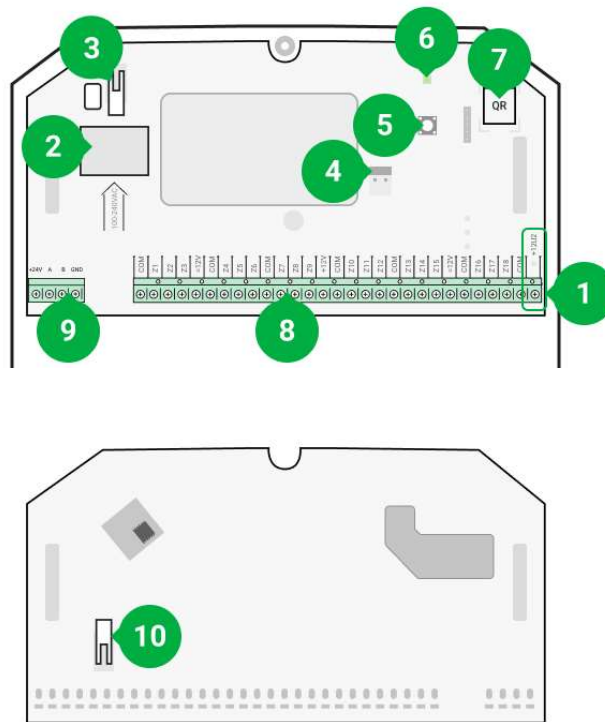

1. Power supply terminals for the 12 V $\equiv$  fire detectors.
2. MultiTransmitter Fibra 110–240 V $\sim$  main power supply input.
3. First tamper button. Signals when trying to remove the lid of the MultiTransmitter Fibra casing.
4. Terminals for connecting a 12 V $\equiv$  backup battery.
5. Power button.
6. LED indicator.
7. MultiTransmitter Fibra QR code and ID (serial number). It is used to pair the device with an Ajax security system.
8. Terminals (zones) for connecting wired detectors.
9. Terminals for connecting MultiTransmitter Fibra to the hub.
10. Second tamper button. Signals when trying to tear off the MultiTransmitter Fibra casing from the surface.

## MultiTransmitter Fibra terminals

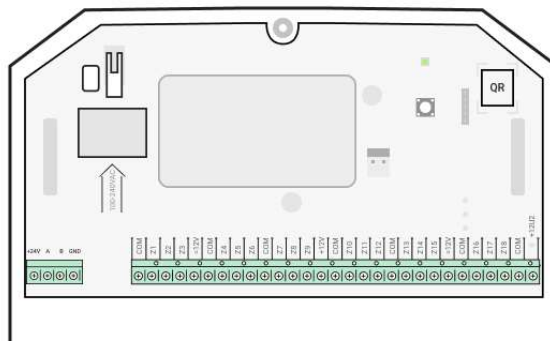

### Terminals for connecting MultiTransmitter Fibra to the hub:

**+24 V** – 24 V $\overline{=}$  power supply terminal.

**A, B** – signal terminals.

**GND** – power ground terminal.

### Terminals for connecting wired devices to MultiTransmitter Fibra:

**Z1–Z18** – inputs for connecting wired devices.

**+12 V** – power supply output for wired devices, voltage 10.5–15 V $\overline{=}$ , up to 1 A in total for all power supply outputs.

**+12V2** – power supply output for fire detectors, voltage 10.5–15 V $\overline{=}$ , up to 0.4 A in total for all power supply outputs.

**COM** – common input for connecting power supply circuits and signal contacts of wired devices.

## Operating principle

Multi Transmitter Fibra is designed to integrate third-party wired devices into an Ajax security system. The integration module receives information about alarms, malfunctions, and events from devices through a wired connection.



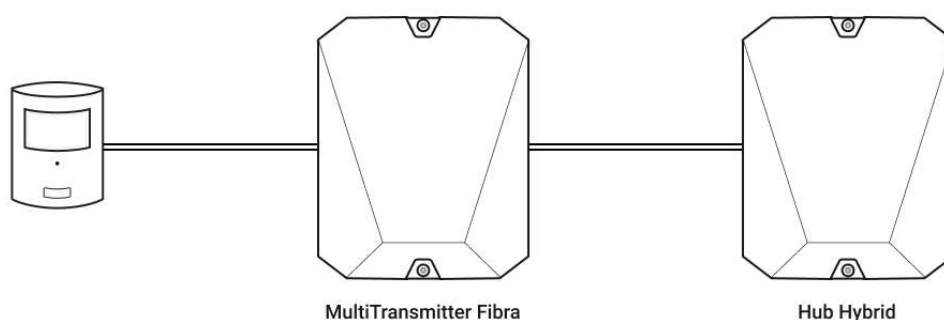

After that, it sends the event to Hub Hybrid using the Fibra data transfer wired protocol. And Hub Hybrid sends messages to users and the security company CMS (central monitoring station).







MultiTransmitter Fibra is used to integrate alarm buttons and call buttons for medical help, motion detectors, as well as opening detectors, vibration, glass breaking, gas, water leaks, fire detectors, and other ones.

The device type is specified in the settings of the zone to which the wired detector or device is connected. The selected type determines the text of alarm messages and events of the connected device, as well as event codes transmitted to the CMS.

### Types of events of wired devices

Type	Icon	Meaning
Intrusion		Alarm when motion, opening, and other detectors are triggered.
Fire		Alarm when fire detectors are triggered.
Medical help		Alarm when pressing the call button for medical assistance.
Panic button		Alarm when the panic button is pressed.
Gas alarm		Alarm when gas concentration is exceeded.

Tamper alarm		Event of a detector or device tamper triggering.
Malfunction		An event caused by a malfunction of a connected detector or device.
Leakage		Alarm caused by flooding.
Custom		<p>The event type is customized by the user.</p> <div style="border: 1px solid black; border-radius: 10px; padding: 10px; margin-top: 10px;">  <p>Not sent to the security company monitoring station and users via SMS.</p> </div>

## Wired devices connection types

- **NO** (normally open).
- **NC** (normally closed).
- **EOL** (connection with one resistor).
- **2EOL** (connection with two resistors).
- **3EOL** (connection with three resistors).

In the Ajax app, you can select the normal state (normally open or normally closed) for each of the terminal pairs: alarm, tamper, and malfunction terminals. This allows connecting any potential-free (“dry”) contact detector of any configuration to MultiTransmitter Fibra.

## Fibra communication protocol

The integration module uses Fibra technology to transmit alarms and events. This is a two-way wired data transfer protocol that provides fast and reliable communication between the hub and integration module. Using the bus connection method, Fibra delivers alarms and events instantly, even if 100 devices are connected to the system.

Fibra supports block encryption with dynamic key and verifies each communication session with devices to prevent sabotage and spoofing. The protocol provides for regular polling of devices by the hub at a specified frequency to control communication and display the state of system devices in Ajax apps.

[Learn more](#)

## Sending events to the Central Monitoring Station (CMS)

An Ajax security system can transmit alarms to the [PRO Desktop](#) monitoring app as well as the Central Monitoring Station (CMS) using **SurGard (Contact ID)**, **SIA DC-09 (ADM-CID)**, **ADEMCO 685**, and other proprietary protocols.

[Which CMSs can an Ajax security system be connected to](#)

**MultiTransmitter Fibra can transmit the following events:**

1. MultiTransmitter Fibra tampers alarm/restoration.
2. Connected devices alarm/restoration.
3. Loss/recovery of communication between MultiTransmitter Fibra and hub.
4. Temporarily disabling/enabling MultiTransmitter Fibra.

5. Temporarily disabling/enabling wired detectors and devices connected to MultiTransmitter Fibra.
6. Unsuccessful attempt to arm the system (if system integrity check is enabled).

When an alarm is received, the monitoring station operator of the security company knows what happened and where the rapid response unit has to be sent. All Ajax devices are addressable, so events, the device type, its assigned name and room can be transmitted to PRO Desktop and the CMS. The list of transmitted parameters may differ depending on the type of the CMS and the selected communication protocol.



The ID and number of the loop (zone) of the integration module and connected devices can be found in their States in Ajax apps. To check the loop (zone) number, open the **States** of the integration module or the connected wired device. The device number corresponds to the loop (zone) number.

## Selecting the installation place

MultiTransmitter Fibra integration module is mounted on a vertical surface with the bundled screws. All the necessary holes for fastening in the casing have already been made. Multi Transmitter Fibra is designed for indoor installation only.



Vertical fixation of the integration module is needed for the tamper to respond if someone tries to detach a device. Learn the battery documentation before installing – some batteries can be mounted only vertically (with terminals upward). Another installation position could cause fast battery degradation.

It is advisable to choose an installation site where the hub is hidden from prying eyes – for example, in the storage room. This helps to reduce the risk of sabotage of the integration module and devices connected to it.

Selecting the installation site for MultiTransmitter Fibra, take into account the parameters that affect the operation of the device module:

- Fibra signal strength.



- Cable length for connecting MultiTransmitter Fibra.
- Cable length for connecting wired devices to MultiTransmitter Fibra.

Consider the placement recommendations when designing the security system project for your object. The security system should be designed and installed by professionals. The list of authorized Ajax partners is [available here](#).

## Where it is forbidden to install MultiTransmitter Fibra

- Outdoors. This can lead to the failure of the integration module.
- Inside premises with temperature and humidity values that do not correspond to the operating parameters. This can lead to the failure of the integration module.
- In places where the integration module has an unstable or low signal strength. This can lead to a connection loss between the hub and the integration module.

## Fibra signal strength

The Fibra signal level is determined by the number of undelivered or corrupted data packages over a certain period. The icon  in the **Devices**  tab in Ajax apps indicates the signal strength:

- **Three bars:** excellent signal strength.
- **Two bars:** good signal strength.
- **One bar:** low signal strength, stable operation is not guaranteed.
- **Crossed out icon:** no signal, stable operation is not guaranteed.

### The following factors affect the signal strength:

- The number of devices connected to one Fibra line.
- Cable length and type.
- The correctness of the wire connections to the terminals.

## Designing the project

It is essential to properly design the security system to install and configure security system devices correctly. The design must take into account the number and types of devices at the object, their exact location and installation height, the length of Fibrá wired lines, the type of cable used, and other parameters.

Tips for designing Fibrá wired systems are available [in this article](#).

## Topologies

At the moment, Ajax security systems support two topologies – **Beam (Radial wiring)** and **Ring**.



Connecting devices using a **Ring** topology will be implemented in the next OS Malevich updates. Hardware update of Hub Hybrid is not required.

**Beam connection (Radial wiring)** occupies one Fibrá line of the hub. Only the segment that remains physically connected to the hub will function in the event of a line break. All devices connected after the breakpoint will lose connection with the hub.



**Ring connection** occupies two Fibrá lines of the hub. If the ring breaks in one place, no device will be disabled. The ring reconfigures into two lines, which continue to operate normally. Users and security company will receive notification about the break.



Beam (Radial wiring)	Ring
<ul style="list-style-type: none"> <li>occupies one Fibra line of the hub</li> <li>up to 8 lines with the same hub</li> <li>up to 2,000 m of wired communication for the same line</li> <li>a terminating resistor is installed at the end of the line</li> </ul>	<ul style="list-style-type: none"> <li>occupies two Fibra lines of the hub</li> <li>up to 4 rings with the same hub</li> <li>up to 500 m of wired communication for the same ring</li> <li>no terminating resistor is installed at the end of the line</li> </ul>

Both device connection topologies can be built on the same hub. For example, you can use two Ring connections and four Beam (Radial) connections.

Different types of devices can be connected to a single Fibra line. For example, you can connect opening detectors, motion detectors with photo verification support, sirens, and keypads to the same line at the same time.

**The devices are connected to the Fibra line one after another, as shown in the diagram. Branching of lines is not allowed.**



For the **Beam (Radial)** topology, be sure to install a 120 Ohm terminating resistor at the end of the line (included in the hub complete set). The terminating resistor

is connected to the signal terminals of the last detector on the line.

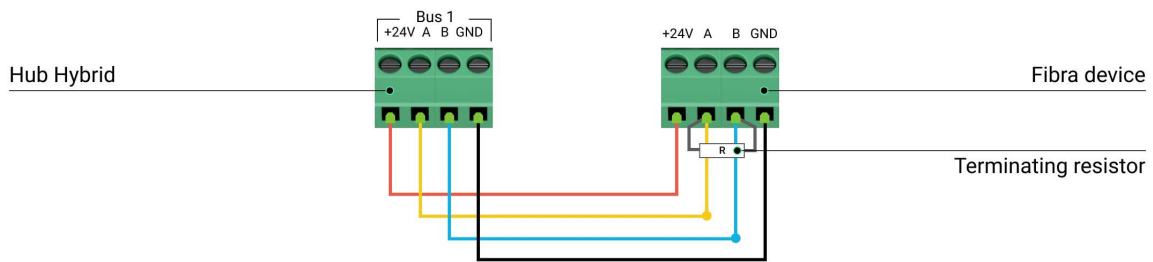

## Cable length and type

### For MultiTransmitter Fibra

The maximum range of a wired connection using the **Beam (Radial)** topology is 2,000 meters, and using the **Ring** topology – 500 meters.



Recommended cable types:

- U/UTP cat.5 4 × 2 × 0.51, copper conductor.
- Signal cable 4 × 0.22, copper conductor.

If you use a different type of cable, the communication range for wired connections may vary. No other types of cables have been tested.

### For wired devices of third-party manufacturers

The maximum cable length for connecting third-party devices to MultiTransmitter Fibra is 400 meters.



Recommended cable types:

- Signal cable 4 × 0.22, copper conductor.
- Signal cable 4 × 0.22, conductor material is aluminum covered with copper.

If you use a different type of cable, the communication range for wired connections may vary. No other types of cables have been tested.

## Verification using a calculator

To make sure that the project is calculated correctly and that such a system will work in real practice, we have developed a [power supply of Fibra calculator](#). The calculator helps to check the quality of communication and cable length for wired Fibra devices with the selected configuration at the system design stage.

## Additional information

The maximum current that Hub Hybrid can supply in total for all Fibra lines is 600 mA. Please note that the total current consumption of the devices in the system depends on the type of cable, its length, the type of connected device, the quality of the connection of conductors, and other factors. Therefore, after selecting devices, we recommend verifying the project using the [power supply of Fibra calculator](#).

Up to 100 devices can be connected to Hub Hybrid at default settings. Each connected to MultiTransmitter Fibra device also occupies one slot within the device limit of the hub.

Multi Transmitter Fibra supports EOL resistors with resistance from 1 to 15 kOhm. The total resistance of all resistors is up to 30 kOhm. To increase anti-sabotage protection, use EOL resistors with different resistances in one detector. The recommended resistance ratio of EOL resistors:  $R_1 = R$ ,  $R_2 = 2 \cdot R$ ,  $R_3 = 3 \cdot R$ .

The integration module has four 10.5-15 V $\overline{=}$  power supply lines: one for the

fire detectors and three — for other devices.

After an alarm, fire detectors require a power reset to restore the normal operation mode. Therefore, the fire detectors power supply should only be connected to a dedicated line. Also, avoid connecting other detectors and devices to power terminals of fire detectors as this may lead to false alarms or incorrect operation of the devices.

## Preparing for installation

### Cable arrangement

When preparing to lay cables, check the electrical and fire safety regulations in your region. Strictly follow these standards and regulations.

It is safest to route cables inside walls, floors, and ceilings: this way they will be invisible and unavailable for intruders. It also ensures their greater durability — the cable will be affected by fewer external factors affecting the conductor's natural wear and insulating layer.

As a rule, security system cables are laid during the construction or repair stage and after wiring at the object.

If impossible to install cables inside the walls, route them so that the cable is sufficiently protected and hidden from prying eyes. For example, in a cable tray or a protective corrugated pipe. It is recommended to hide them. For example, behind the furniture.

We recommend using protective pipes, cable conduits, or corrugated pipes to protect cables, regardless of whether they are routed inside the wall or not. The cables should be arranged carefully: no sagging, tangling, or twisting is allowed.

Take into account the places of possible signal interference. If the cable is routed near motors, generators, transformers, power lines, control relays, and

other sources of electromagnetic interference, use twisted-pair cable in these areas.

## Cable routing

When laying cables for a security system, you need to know not only the general requirements and rules for electrical installation work but also the specific installation features of each device: installation height, mounting method, how the cable is inserted into the enclosure, and other parameters.

Before installation, we recommend you read the [Selecting the installation site](#) section of this manual, as well as the manual for a third-party wired device. If you have questions about the operation of third-party wired devices, please contact the technical support of the manufacturer of this device.

Try to avoid any deviations from the security system project design. Violation of the basic installation rules and recommendations of this manual, as well as the instructions of the manufacturer of third-party wired devices, may lead to incorrect operation of the integration module, false alarms of connected wired devices, and loss of connection with MultiTransmitter Fibra.

Check the cables for bends and physical damage before installation. Replace the damaged cables.

Signal cables of Fibra devices must be laid at a distance of at least 50 cm from the power cables when lying parallel, and, if they intersect, it must be at a 90° angle.

Observe the permissible bend radius of the cable. It is specified by the manufacturer in the cable specifications. Otherwise, you risk damaging or breaking the conductor.

**Fibra devices are connected to the line one after another. Branching of lines is not allowed.**

## Preparing cables for connection

Remove the insulating layer of the cable and strip the cable with a special insulation stripper. It strips the cable properly without damaging the conductor.

The ends of the wires that will be inserted into the detector's terminals should be tinned or crimped with a sleeve. This ensures reliable connection and protects the conductor from oxidation.

Recommended cable lug sizes: 0.75 to 1 mm<sup>2</sup>.



Features of enclosures of third-party wired devices may exclude the use of insulated ferrules. To connect such devices, you can use a wire-end ferrule without insulation with a cross-section of 0.5 mm<sup>2</sup> or more.

## Installation and connection



Before installing MultiTransmitter Fibra, make sure that you have selected the optimal location and that it meets the requirements of this manual. To reduce the risk of sabotage, the cables must be hidden from view and located in a difficult place for intruders to access. Ideally, the cables should be mounted in walls, floors, or ceilings. Run the [Fibra signal strength test](#) before final installation.

When connecting to the terminals of the device, do not twist the wires together, but solder them. The ends of the wires that will be inserted into the terminals should be tinned or crimped with a special sleeve. This will ensure a reliable connection. **Observe the safety procedures and the rules for electrical installation work when connecting the integration module and third-party devices.**

## Connecting MultiTransmitter Fibra to the hub

1. Remove the MultiTransmitter Fibra casing lid by unscrewing the bottom and top screws with the bundled hex wrench.
2. Remove the MultiTransmitter Fibra board from the holders by pulling them to the sides.
3. Prepare cable openings in advance by carefully breaking out the perforated parts of the casing.



4. Fasten the casing to a vertical surface at the chosen installation location using the bundled screws. When attaching, use all fixing points on the casing. One of them is in the perforated part above the tamper – it is required for tamper triggering in case of any attempt to detach MultiTransmitter Fibra casing.

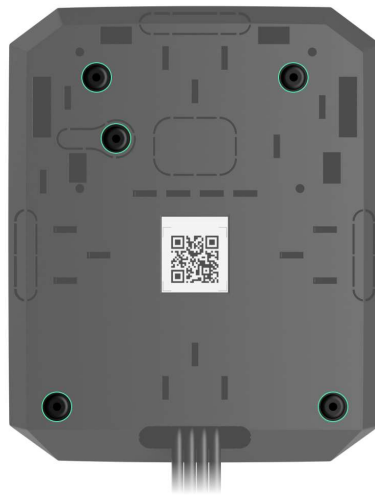

5. Disconnect the external power and the hub backup battery.

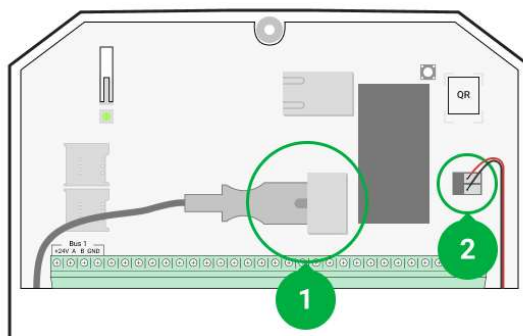

- 1 – External power.
- 2 – Backup battery.



To comply with the INCERT requirements, use the Screw terminal block Adapter to connect the external power supply. [Read more.](#)

6. Pull the cable into the hub. Connect the wires to the hub line.

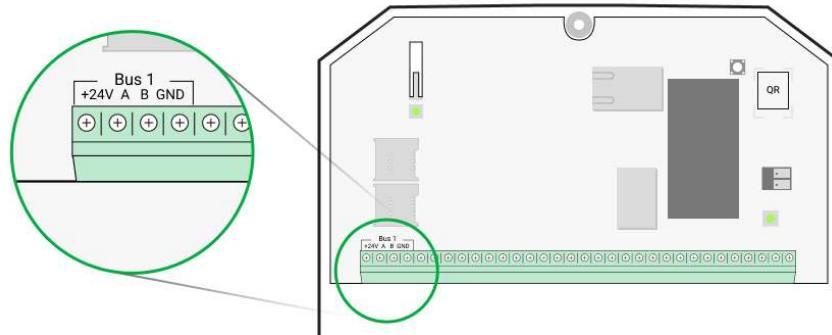

**+24V** – power supply terminal of 24 V<sub>DC</sub>.

**A, B** – signal terminals.

**GND** – power ground terminal.

7. Pull the cable from the hub into the casing of the integration module through the holes made.

8. Install the MultiTransmitter Fibra board into the casing on special holders.

9. If the integration module is not the last in the connection line, prepare a second cable in advance. The ends of the wires of the first and second cables that will be inserted into the terminals of the device should be tinned and soldered together or crimped with a special sleeve.

10. Connect the wires to the terminals according to the diagram below. Follow the polarity and connection order of the wires. Securely fasten the conductors to the terminals.

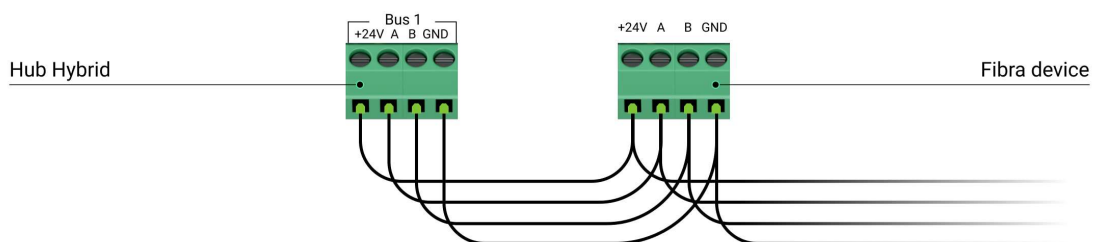

**+24V** – power supply terminal of 24 V<sub>DC</sub>.

**A, B** – signal terminals.

**GND** — power ground terminal.

11. When using **Beam (Radial) topology**: if the integration module is the last in a line, install a terminating resistor by connecting it to the signal terminals of the device. For the **Ring** topology terminating resistor is not needed.

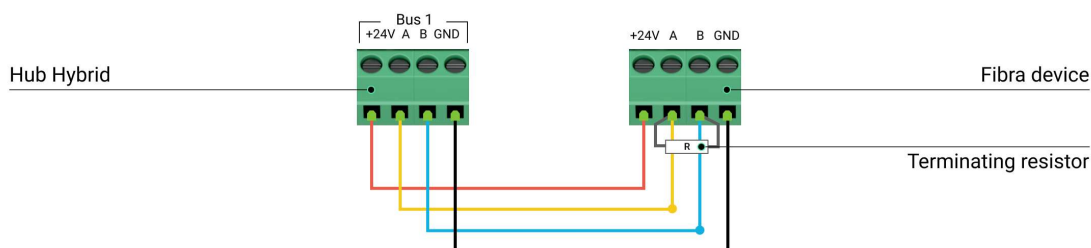

### More about topologies to connect Ajax devices



If possible, we recommend connecting devices using the **Ring** topology (hub—device—hub). This improves the antisabotage protection of the system.

12. Secure the cables with cable ties using special mounts in the casing.

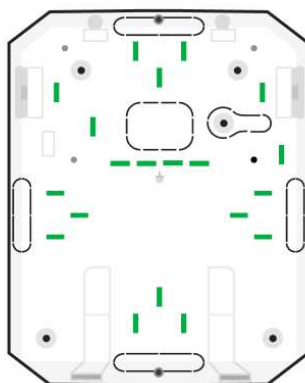

13. Install a 12V<sub>DC</sub> backup battery on the special holders in a casing. Please note that MultiTransmitter Fibra cannot be connected to third-party power supply units.



Use 12 V<sub>DC</sub> batteries with a capacity of 4 or 7 A·h. For such batteries, special holders in the casing are designed. You can also use similar batteries of a different capacity, of the matching size, and with a charging time of no more than 30 hours. The maximum dimensions of the battery to be installed in the casing are 150 × 65 × 94 mm, and the weight is 5 kg.

14. Connect the backup battery with the bundled cable to the board terminals according to the wiring diagram below. Follow the polarity and connection order of the wires. Securely fasten the conductors to the terminals.

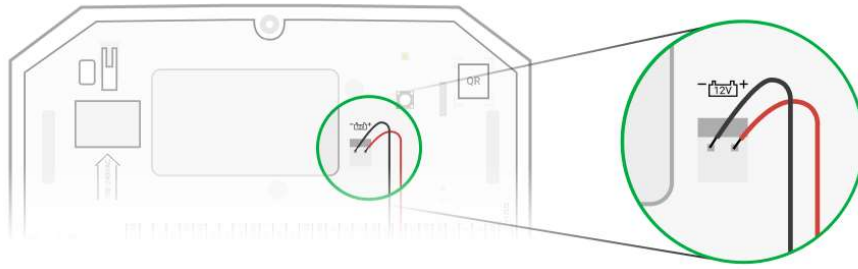

15. Connect the external 110-240 V~ power supply to the integration module.
16. Connect the backup battery and external power supply to the hub. Turn on the hub.
17. Add an integration module to the system.
18. Run a Fibra signal strength test. The recommended signal strength is two or three bars. If the signal strength is one or zero bars, check the connection's correctness and the cable's integrity.
19. Install the lid on the integration module casing. Secure it with screws at the bottom and top of the lid using the bundled hex wrench.

## Connecting wired devices to MultiTransmitter Fibra

1. Remove the MultiTransmitter Fibra casing lid by unscrewing the bottom and top screws with the bundled hex wrench.
2. Turn off MultiTransmitter Fibra by holding down the on/off button.
3. Disconnect 110-240 V~ external power and MultiTransmitter Fibra backup battery.
4. Select the MultiTransmitter Fibra zone to which you want to connect a device.
5. Pull the third-party device cable into the integration module casing.
6. Connect the device to MultiTransmitter Fibra, securely fixing the wires in the terminals. The wiring diagram can be found in the user manual provided by the manufacturer of the wired device.



Read the manufacturer's instructions before connecting the device to MultiTransmitter Fibra.

## How to connect a wired detector or device to MultiTransmitter Fibra

7. Secure the cable with cable ties using special mounts inside the casing.

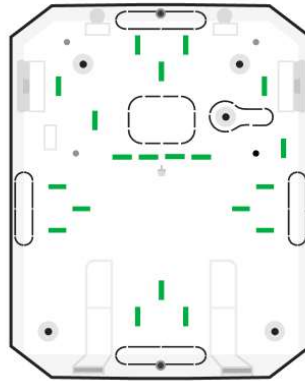

8. Connect 110-240 V~ external power and backup battery to MultiTransmitter Fibra.

9. Add device to the system.

10. Test the operation of the connected wired device.

## Adding to the system



MultiTransmitter Fibra is compatible only with Hub Hybrid (2G) and Hub Hybrid (4G). control panels. Only verified partners can add and configure Fibra devices in Ajax PRO apps.

Types of accounts and their rights

## Before adding MultiTransmitter Fibra

1. Install the Ajax app. Create an account if you don't already have one.

2. Add a hub compatible with the integration module to the app, set the necessary settings, and create at least one virtual room.

3. Make sure that the hub is on and has Internet access via Ethernet and/or cellular network. You can do this in the Ajax app or by looking at the LED on the hub board. It should light up white or green.
4. Make sure the hub is disarmed and not updated by looking at its state in the [Ajax app](#).
5. Make sure the MultiTransmitter Fibra integration module is physically connected to the hub.

## How to add MultiTransmitter Fibra

### To add an integration module manually

1. Open the [Ajax PRO app](#). Select the hub you want to pair MultiTransmitter Fibra with.
2. Go to the **Devices**  tab and click **Add device**.
3. Specify a name for the integration module.
4. Scan or enter the QR code manually. The QR code is located on the integration module board, on the back of the casing, and on the package.
5. Select a virtual room and a security group if the [group mode](#) is enabled.
6. Press **Add**.
7. Turn on the integration module by holding the on/off button.

### For the integration module to be added automatically

1. Open the [Ajax PRO app](#). Select the hub to which you want to add physically connected devices.
2. Go to the **Devices**  tab and click **Add Device**.
3. Select **Add All Fibra Devices**. The hub will scan the Fibra lines. After scanning, all devices physically connected to the hub will be shown on the **Devices** tab. The order of the devices will depend on which line they are connected to.
4. In the list of available for adding devices, click on the one you need. After pressing, the LED indicator of this device will start flashing. This way, you'll

know exactly which device you're adding, how to name it correctly, and which room and group it should be connected to.

5. To add a device, specify a name, room, and security group if the group mode is enabled. Press **Add**. If the device was successfully added to the hub, it disappears from the list of devices available for adding and displays on the **Devices** tab in the app.



MultiTransmitter Fibra works with one hub only. After connecting to a new hub, the integration module stops exchanging commands with the old one. After adding to the new hub MultiTransmitter Fibra is not removed from the list of the old hub. You should do it manually in Ajax apps.

## How to add a connected wired device



In the Ajax security system, each connected to the MultiTransmitter Fibra device occupies one slot within the hub's device limit.

1. In the Ajax PRO app, go to the **Devices**  tab.
2. Find **MultiTransmitter Fibra** in the device list.
3. Click on the **Devices** menu under the integration module icon.
4. Click **Add Device**.
5. Assign a name to the device.
6. Select the wired zone to which the device will be physically connected.
7. Select a virtual room and a security group if the group mode is enabled.
8. Press **Add Device**. The device will be added within 30 seconds.



The device status update depends on the Jeweller/Fibra settings; the value by default is 36 seconds.



If the connection fails, check if the wired connection is valid and try again. If the hub already has the maximum number of devices added (for Hub Hybrid, the default is 100), you will get an error notification when you add one.

## Functionality testing

An Ajax security system has several tests for choosing the right installation place for the devices. Tests do not start immediately, but after no more than one polling interval “hub—device”.

**Fibra Signal Strength Test** is available for MultiTransmitter Fibra. The test allows you to determine the strength and stability of the signal at the installation site.

### How to run test





1. Select the hub if you have several of them or if you use **Ajax PRO app**.
2. Go to the **Devices**  menu.
3. Select **MultiTransmitter Fibra**.
4. Go to the MultiTransmitter Fibra settings by clicking on the gear icon .
5. Select the **Fibra Signal Strength Test**.
6. Perform the test following the tips of the app.

## Icons







Icons show some device states. You can view them in Ajax apps in the **Devices**  tab.



















### MultiTransmitter Fibra icons



Icon	Meaning
	Fibra signal strength — displays the signal strength between the hub and the integration module. Recommended value is 2–3 bars.  <u><a href="#">Learn more</a></u>

	A fire detector connected to MultiTransmitter Fibra has registered an alarm.
	The charge level of the MultiTransmitter Fibra backup battery. <a href="#">Learn more</a>
	MultiTransmitter Fibra has a malfunction. A list of malfunctions is available in the <a href="#">States</a> of the integration module.
	MultiTransmitter Fibra is temporarily disabled. <a href="#">Learn more</a>
	MultiTransmitter Fibra tamper triggering events are temporarily disabled. <a href="#">Learn more</a>

## Icons of connected devices

Icon	Meaning
	<a href="#">Chime</a> function is enabled.
 	<a href="#">Delay When Entering and/or Exit</a> is enabled.
	The device operates in the <a href="#">Always active</a> mode.
	The device will work when <a href="#">Night Mode</a> is enabled.
	The device state is OK. <i>Displayed for EOL, NC, and NO connections only.</i>
	The device is short-circuited. <i>Displayed for EOL, NC, and NO connections only.</i>

	The device tamper state is OK. <i>Displays for 2EOL and 3EOL connections only.</i>
	Device tamper alarm. <i>Displays for 2 EOL and 3 EOL connections only.</i>
	The state of the intrusion sensors is OK. <i>Displayed for 2EOL and 3EOL connections only.</i>
	Intrusion alarm. <i>Displayed for 2EOL and 3EOL connections only.</i>
	The state of the call button for medical help is OK.
	Alarm when pressing the call button for medical help.
	The state of the alarm button is OK.
	Alarm when the alarm button is pressed.
	The state of the fire sensor is OK.
	The device has detected a fire alarm.
	The state of the gas sensor is OK.
	Gas alarm.
	The device state is OK. <i>Displayed for 2EOL and 3EOL connections only.</i>
	Device malfunction is detected. <i>Displayed for 2EOL and 3EOL connections only.</i>
	The state of the flooding sensor is OK.
	Alarm caused by the flooding.
	The state of the device for which the custom type of event is selected is OK.
	The alarm of the device for which the custom type of event is selected.

	The device is automatically <u>disabled due to exceeding the number of alarms.</u>
	The device is <u>automatically disabled by the restoration timer.</u>
	The device is <u>temporarily disabled</u> by the system user.

## States

### MultiTransmitter Fibra states

The states contain information about the integration module and its operating parameters. MultiTransmitter Fibra states can be found in the Ajax app:

1. Go to the **Devices**  tab.
2. Select MultiTransmitter Fibra in the device list.

Parameter	Meaning
Malfunction	<p>Pressing  opens the list of MultiTransmitter Fibra malfunctions.</p> <p>The field is displayed only if a malfunction is detected.</p>
Fibra signal strength	<p>Signal strength between the hub and MultiTransmitter Fibra. The recommended value is two or three bars.</p> <p>Fibra is the protocol for transmitting MultiTransmitter Fibra events and alarms.</p> <p><a href="#"><u>Learn more</u></a></p>
Connecting via Fibra	<p>Connection state between the hub and MultiTransmitter Fibra:</p> <ul style="list-style-type: none"> <li>• <b>Online</b> – integration module is connected to the hub.</li> </ul>

	<ul style="list-style-type: none"> <li>• <b>Offline</b> — the integration module has lost connection with the hub. Check the integration module connection to the hub.</li> </ul>
Line voltage	The voltage value on the Fibra line to which the integration module is connected.
Battery charge	<p>The charge level of the connected battery. Specified as a percentage in 5% increments.</p> <p><b><u>How battery charge is displayed in Ajax apps</u></b></p>
Lid	<p>The state of the tampers that responds to detachment of the device from the surface or the casing opening:</p> <ul style="list-style-type: none"> <li>• <b>Closed</b> — the casing lid is closed. Normal state of the casing.</li> <li>• <b>Open</b> — the casing lid is open or the casing integrity is compromised otherwise. Check the condition of device casing.</li> </ul> <p><b><u>Learn more</u></b></p>
External power	<p>The presence of external power supply 110–240 V~:</p> <ul style="list-style-type: none"> <li>• <b>Connected</b> — the external power is connected to the integration module.</li> <li>• <b>Disconnected</b> — the external power is disconnected. Check the connection of the power cable to the integration module.</li> </ul>
Detectors Power Line	<p>Status of power terminals of the third-party wired devices:</p> <ul style="list-style-type: none"> <li>• <b>OK</b> — terminals are in normal condition.</li> <li>• <b>Short-circuited</b> — terminals are short-circuited.</li> </ul>
Fire Detectors Power Line	Status of power terminals of third-party fire detectors:

	<ul style="list-style-type: none"> <li>• <b>OK</b> – terminals are in normal condition.</li> <li>• <b>Short-circuited</b> – terminals are short-circuited.</li> </ul>
Deactivation	<p>Shows the status of the device temporary deactivation function:</p> <ul style="list-style-type: none"> <li>• <b>No</b> – the device operates in normal mode and transmits all events.</li> <li>• <b>Lid only</b> – the hub admin disabled notifications about tamper alarms.</li> <li>• <b>Entirely</b> – the device is completely excluded from the system operation by the hub admin. The device does not follow system commands and does not report alarms or other events.</li> </ul> <p><a href="#">Learn more</a></p>
Firmware	MultiTransmitter Fibra firmware version.
ID	MultiTransmitter Fibra ID/serial number. Also located on the integration module board, the back part of the casing, and on the packaging.
Device No.	The MultiTransmitter Fibra loop (zone) number.
Line No.	The number of the Fibra line of a hub to which MultiTransmitter Fibra is physically connected.

## States of connected devices

The states display information about the device and its operating parameters. States of connected to MultiTransmitter Fibra devices can be found in Ajax apps:

1. Go to the **Devices**  tab.
2. Find **MultiTransmitter Fibra** in the list.
3. Click on **Devices** under the MultiTransmitter Fibra icon.

#### 4. Select the device from the list.

Parameter	Meaning
Malfunction	<p>After clicking on , a list of malfunctions of the connected wired device opens.</p> <p>The field is displayed only if a malfunction is detected.</p>
Delay When Entering, s	<p>Delay time when entering: 5 to 120 seconds.</p> <p>Delay when entering (alarm activation delay) is the time the user has to disarm the security system after entering the secured area.</p> <p><a href="#"><u>Learn more</u></a></p>
Delay When Leaving, s	<p>Delay time when leaving: 5 to 120 seconds.</p> <p>Delay when leaving (arming delay) is the time the user has to leave the secured area after arming.</p> <p><a href="#"><u>Learn more</u></a></p>
Night Mode Delay When Entering, s	<p>Delay time when entering in <b>Night Mode</b>: 5 to 120 seconds.</p> <p>Delay when entering (alarm activation delay) is the time the user has to disarm the security system after entering the secured area.</p> <p><a href="#"><u>Learn more</u></a></p>
Night Mode Delay When Leaving, s	<p>Delay when leaving in <b>Night Mode</b>: 5 to 120 seconds.</p> <p>Delay when leaving (arming delay) is the time the user has to leave the secured area after arming.</p> <p><a href="#"><u>Learn more</u></a></p>



<p>MultiTransmitter Fibra name</p>	<p>The state of MultiTransmitter Fibra that the wired device is connected to:</p> <ul style="list-style-type: none"> <li>• <b>Online</b> — MultiTransmitter Fibra is connected to the hub.</li> <li>• <b>Offline</b> — MultiTransmitter Fibra is not connected to the hub.</li> </ul>
<p>Device state</p> <p><b>Displayed for Without EOL and EOL connection types</b></p>	<p>The status of the connected wired device:</p> <ul style="list-style-type: none"> <li>• <b>OK</b> — the device is normally operated.</li> <li>• <b>Alert</b> — the device detected an alarm.</li> <li>• <b>Contacts Damaged</b> — displayed if there is a broken connection with the device. <b>State is only available in case of an EOL NC connection.</b></li> </ul>
<p>Tamper sensor</p> <p><b>Displayed for 2EOL and 3EOL connection types</b></p>	<p>Tamper status of the connected device:</p> <ul style="list-style-type: none"> <li>• <b>OK</b> — the tamper is normally operated.</li> <li>• <b>Alert</b> — the alarm of a device tamper.</li> </ul>
<p>“Name of the selected event type” sensor</p> <p><b>Displayed for 2EOL and 3EOL connection types</b></p>	<p>The status of the connected wired device:</p> <ul style="list-style-type: none"> <li>• <b>OK</b> — the connected device is normally operated.</li> <li>• <b>Alert</b> — the connected device detected an alarm.</li> <li>• <b>Shorted out</b> — terminals to which the device is connected are short-circuited.</li> </ul>
<p>Always Active</p>	<p>If the option is active, connected to MultiTransmitter Fibra device is constantly armed and reports alarms.</p> <p>You can configure the option only for the <b>Intrusion</b> and <b>Custom</b> event types. Devices for which other event types are selected are always active by default.</p> <p><a href="#"><b>Learn more</b></a></p>

<p>Device resistance</p> <p><b>Displayed for EOL, 2EOL, and 3EOL connection types</b></p>	<p>The total resistance of the resistor (or resistors) connected to the device is measured automatically.</p> <p>Values can also be set manually in 100-ohm increments.</p>
<p>Deactivation</p>	<p>Allows the user to disable the device without removing it from the system.</p> <p>Two options are available:</p> <ul style="list-style-type: none"> <li>• <b>No</b> – the device operates in normal mode and transmits all events.</li> <li>• <b>Entirely</b> – the device is completely excluded from the system operation by the hub admin. The device does not follow system commands and does not report alarms or other events.</li> </ul> <p><b><u>Learn more</u></b></p> <p>You can also separately configure the device disconnecting:</p> <ul style="list-style-type: none"> <li>• <b>By number of alarms</b> – the device is automatically disconnected by the system when the set number of alarms is exceeded.</li> <li>• <b>By timer</b> – the device is automatically disconnected when the restoration timer expires.</li> </ul> <p>The feature is configured in the Ajax PRO apps.</p> <p><b><u>Learn more</u></b></p>
<p>Wired devices №</p>	<p>MultiTransmitter Fibra zone number, to which a wired detector or device is physically connected.</p>
<p>Device No.</p>	<p>Device loop (zone) number.</p>

# Settings

## MultiTransmitter Fibra settings

To change the MultiTransmitter Fibra settings:



1. Go to the **Devices**  tab.
2. Select **MultiTransmitter Fibra** from the list.
3. Go to **Settings** by clicking on the gear icon .
4. Set the parameters.
5. Click **Back** to save the new settings.

Settings	Meaning
Name	<p>Integration module name. Displayed in the list of hub devices, SMS text, and notifications in the events feed.</p> <p>To change the name, click on the text field.</p> <p>The name can contain up to 12 Cyrillic characters or up to 24 Latin characters.</p>
Room	<p>Choosing a MultiTransmitter Fibra virtual room.</p> <p>The room name is displayed in the text of SMS and notifications in the event feed.</p>
Activate the siren if the power supply of detectors is short-circuited	<p>If the option is active, the <b>sirens</b> connected to the system are activated when a short circuit is detected in the power supply line of devices connected to the integration module.</p>
Fibra Signal Strength Test	<p>Switches the integration module to the Fibra Signal Strength Test mode.</p> <p>The test allows you to check the Fibra signal strength between the hub and the integration module to find the optimal installation spot.</p>

	<a href="#"><u>Learn more</u></a>
User Manual	Opens MultiTransmitter Fibra User Manual in the Ajax app.
Deactivation	<p>Allows the user to disable the device without removing it from the system.</p> <p>Three options are available:</p> <ul style="list-style-type: none"> <li>• <b>No</b> – the device operates in normal mode and transmits all events.</li> <li>• <b>Entirely</b> – the device will not execute system commands or participate in automation scenarios, and the system will ignore alarms and other notifications of the device.</li> <li>• <b>Lid only</b> – the system will ignore notifications about the triggering of the device tamper only.</li> </ul> <p><a href="#"><u>Learn more about temporary deactivation of devices</u></a></p> <p><b>The system only ignores the disabled device. Devices connected via MultiTransmitter Fibra will continue to operate in normal mode.</b></p> <p>The system can also automatically deactivate devices when the set number of alarms is exceeded or when the restoration timer expires.</p> <p><a href="#"><u>Learn more about auto deactivation of devices</u></a></p>
Unpair Device	Disconnects MultiTransmitter Fibra from the hub, and deletes its settings.

## Settings of connected devices

To change the connected device settings, in the Ajax app:

1. Go to the **Devices**  tab.
2. Find **MultiTransmitter Fibra** in the list.
3. Click on **Devices** under the MultiTransmitter Fibra icon.
4. Select the device from the list.
5. Go to **Settings** by clicking on the gear icon .
6. Set the parameters.
7. Click **Back** to save the new settings.

**Without EOL   EOL   2EOL   3EOL**

---

Setting	Meaning
Name	<p>Wired device name. Displayed in the list of hub devices, SMS text, and notifications in the events feed.</p> <p>To change the name, click on the text field.</p> <p>The name can contain up to 12 Cyrillic characters or up to 24 Latin characters.</p>
Room	<p>Selecting the device's virtual room.</p> <p>The room name is displayed in the text of SMS and notifications in the event feed.</p>
Input type	<p>Selecting the connection type of a third-party device:</p> <ul style="list-style-type: none"> <li>• Without EOL</li> <li>• EOL</li> <li>• 2EOL</li> <li>• 3EOL</li> </ul>

Status by default	<p>Selecting the normal contact state of the connected detector or device:</p> <ul style="list-style-type: none"><li>• <b>Normally closed</b></li><li>• <b>Normally open</b></li></ul>
Event type	<p>Selecting the event type of the connected device:</p> <ul style="list-style-type: none"><li>• Intrusion</li><li>• Fire</li><li>• Medical help</li><li>• Panic button</li><li>• Gas alarm</li><li>• Tamper alarm</li><li>• Malfunction</li><li>• Leakage</li><li>• Custom (<b>not sent to users via SMS and to the security company monitoring station</b>)</li></ul> <p>The text of notifications in the event feed and SMS, as well as the code transmitted to the security company monitoring station depends on the selected event type.</p>
Operating mode	<p>The operating mode of the connected device:</p> <ul style="list-style-type: none"><li>• <b>Bistable</b> – for example, an opening detector. After an alarm, a restoration event is not sent if the detector returns to the normal state.</li><li>• <b>Pulse</b> – for example, a motion detector. After an alarm, no restoration message is sent if the detector returns to a normal state.</li></ul> <p>Be sure to set a type that matches the connected device.</p>

	<p>The pulsed detector in the bistable mode generates unnecessary restoration events.</p> <p>A bistable detector in pulsed mode, on the contrary, will not send restoration events.</p>
<p>Always Active</p>	<p>If the option is active, connected to MultiTransmitter Fibra device is constantly armed and reports alarms.</p> <p>You can configure the option only for the <b>Intrusion</b> and <b>Custom</b> event types. Devices for which other event types are selected are always active by default.</p> <p><a href="#"><u>Learn more</u></a></p>
<p>Delay When Entering, s</p>	<p>Delay time when entering: 5 to 120 seconds.</p> <p>Delay when entering (alarm activation delay) is the time the user has to disarm the security system after entering the secured area.</p> <p><a href="#"><u>Learn more</u></a></p>
<p>Delay When Leaving, s</p>	<p>Delay time when leaving: 5 to 120 seconds.</p> <p>Delay when leaving (arming delay) is the time the user has to leave the secured area after arming the system.</p> <p><a href="#"><u>Learn more</u></a></p>
<p>Arm in Night Mode</p>	<p>If the option is active, the device connected to the integration module will switch to armed mode when the system is set to <b>Night Mode</b>.</p> <p><a href="#"><u>Learn more</u></a></p>
<p>Night Mode Delay When Entering, s</p>	<p>Delay time when entering in <b>Night Mode</b>: 5 to 120 seconds.</p> <p>Delay when entering (alarm activation delay) is the time the user has to disarm the security system after entering the secured area.</p> <p><a href="#"><u>Learn more</u></a></p>

<p>Night Mode Delay When Leaving, s</p>	<p>Delay when leaving in <b>Night Mode</b>: 5 to 120 seconds.</p> <p>Delay when leaving (arming delay) is the time the user has to leave the secured area after arming.</p> <p><a href="#"><u>Learn more</u></a></p>
<p>Pulse time</p>	<p>Pulse time of a detector or device for detecting an alarm:</p> <ul style="list-style-type: none"> <li>• 20 ms.</li> <li>• 100 ms (by default).</li> <li>• 1 s.</li> </ul> <p>An alarm will be activated if the pulse from the device lasts longer than specified in this setting. This can be used to filter false triggerings.</p>
<p>Alert with a siren if alarm is detected</p>	<p>If the option is active, the <a href="#"><u>sirens</u></a> connected to the system are activated when an alarm is detected.</p>
<p>Chime</p>	<p>Opens the Chime settings. The function works only for bistable devices.</p> <p><b>Notifications will not work for sensors in pulse mode or Always active mode.</b></p> <p><a href="#"><u>How to set up Chime</u></a></p> <p><a href="#"><u>What is Chime</u></a></p>
<p>Deactivation</p>	<p>Allows the user to disable the device without removing it from the system.</p> <p>Two options are available:</p> <ul style="list-style-type: none"> <li>• <b>No</b> – the device operates in normal mode and transmits all events.</li> <li>• <b>Entirely</b> – the device is completely excluded from the system operation by the hub admin. The device does not follow system</li> </ul>

commands and does not report alarms or other events.

### [Learn more](#)

You can also separately configure disconnecting of the device:

- **By number of alarms** – the device is automatically disconnected by the system when the set number of alarms is exceeded.
- **By timer** – the device is automatically disconnected when the restoration timer expires.

The feature is configured in the Ajax PRO apps.

### [Learn more](#)

## How to set up Chime

When **Chime** are enabled, the sirens make a special sound to indicate that the opening detectors are triggered when the system is disarmed. The feature is used, for example, in stores, to notify employees that someone has entered the building.

Chime is set in two stages: setting up opening detectors and setting up sirens.

### [Learn more](#)



## How to set up wired opening detector



Before setting up the Chime feature, make sure that a wired opening detector is connected to MultiTransmitter Fibra and the following options have been configured in the detector settings in the Ajax app:

- The event type is intrusion.
- Operating mode: bistable.

- Always active – disabled.

1. Go to the **Devices**  tab.
2. Find **MultiTransmitter Fibra** in the list.
3. Click on the **Devices** menu under the integration module icon.
4. Select the device from the list.
5. Go to the device **Settings** by clicking on the gear icon .
6. Go to the **Chime** menu.
7. Activate the **If device is triggered** option.
8. Select the chime sound: 1 to 4 short beeps. After that, the Ajax app will play the selected sound.
9. Click **Back** to save the settings.
10. Set up the siren.

### How to set up a siren for the Chime function

## How to reset fire detectors alarm

In case of alarms of the fire detectors connected to MultiTransmitter Fibra, the window prompting of the need to reset the alarms is displayed in the Ajax app. This permits the detectors to return to their normal state and further respond to a fire.



If the detectors are not reset after the fire alarm, they will not respond to the next fire, as they will remain in alarm mode.

### There are two ways to reset fire detectors:

1. By clicking the button in the notification in the app.

2. Via the MultiTransmitter Fibra menu: click on the red button opposite the integration module.

## MultiTransmitter Fibra indication

Multi Transmitter Fibra reports some states with an LED indicator on the device board.

LED indication	Event	Note
Lights up in white.	MultiTransmitter Fibra is connected to the hub. The external power supply is disconnected.	
Lights up in red.	MultiTransmitter Fibra is not connected to the hub.	For example, the hub is turned off or the integration module has no connection with the hub via the Fibra protocol.
Once every 10 seconds, lights up in green for 1 second and goes out.	The external power supply is disconnected.	Lights up in white if there is connection with hub.  Lights up in red if there is no hub connection.
Goes out, and then lights up in green and gradually goes out to complete disabling.	Turning off MultiTransmitter Fibra after holding down the on/off button.	
Smoothly lights up and goes out after an alarm or a tamper trigger	Low voltage of the power supply line.  <b>Voltage of 7 V<sup>-</sup> or less is considered low.</b>	

## Malfunctions

If a malfunction is detected in the integration module or a wired device connected to it, a malfunction counter will be displayed in Ajax apps in the upper left corner of the device icon.

All malfunctions can be seen in the States of devices. Fields with malfunctions will be highlighted in red.

The integration module and wired devices connected to it can report malfunctions to the security company monitoring station as well as to users in the form of push notifications and SMS.

## MultiTransmitter Fibra malfunctions

- The casing of the integration module is open or torn off from the surface (tamper triggering).
- No connection between the integration module and the hub via the Fibra protocol.
- Battery discharged.
- Battery charges over 40 hours.
- The backup battery connection failed (the battery is not physically connected or there are hardware problems: for example, the connection cable is defective).
- Low voltage of MultiTransmitter Fibra power supply line.
- The power supply line of detectors is short-circuited.

## Malfunctions of connected devices

- The device enclosure is open (tamper triggering).
- No connection between the integration module and the device (contacts damaged).
- Incorrect connection of resistors (resistor resistance error).
- The system detected a short circuit in the device contacts.

## Maintenance

Regularly check the functionality of the integration module and wired devices connected to it. The optimal frequency of check is once every three months. We recommend you check the fixation tightness of the wires in the terminals of the integration module.

Clean the casing from dust, cobwebs, and other contaminants as they emerge. Use a soft dry cloth suitable for equipment care. Do not use substances that contain alcohol, acetone, gasoline, and other active solvents to clean the device.

## Technical specifications

[All technical specifications of MultiTransmitter Fibra](#)

[Compliance with standards](#)

[INCERT installation compliance](#)

## Complete set

1. MultiTransmitter Fibra.
2. Casing.
3. Power cable.
4. Screw terminal block Adapter (only for INCERT compliance).
5. 12 V $\equiv$  battery connection cable.
6. Installation kit
7. Quick Start Guide.

## Warranty

The warranty for the Limited Liability Company "Ajax Systems Manufacturing" products is valid for 2 years after purchase.

If the device does not function correctly, please contact the Ajax Technical Support first. In most cases, technical issues can be resolved remotely.

[Warranty Obligations](#)

[User Agreement](#)

**Contact Technical Support:**

- [e-mail](#)
- [Telegram](#)

Subscribe to the newsletter about safe life. No spam

**Subscribe**